

**BAKERY PLANT, TRAILER-MOUNTED, M-1945: DOUGH MIXING AND MAKEUP OUTFIT (MIXER)**

REFERENCE: L010-7360-201-20-2,-3,-4,-5,-6. C9100-IL

**Approved for public release; distribution is unlimited.**

Intervals are based on normal operation. Reduce to compensate for abnormal operation and severe conditions. During inactive periods, sufficient lubrication must be performed for adequate preservation.

Clean fittings before lubricating.

Clean parts with SD (Solvent, dry cleaning).

Dry before lubricating.

Relubricate after washing or fording.

Broken arrow shafts indicate lubrication points on both sides of the equipment.

**LUBRICANT · INTERVAL**

**INTERVAL · LUBRICANT**

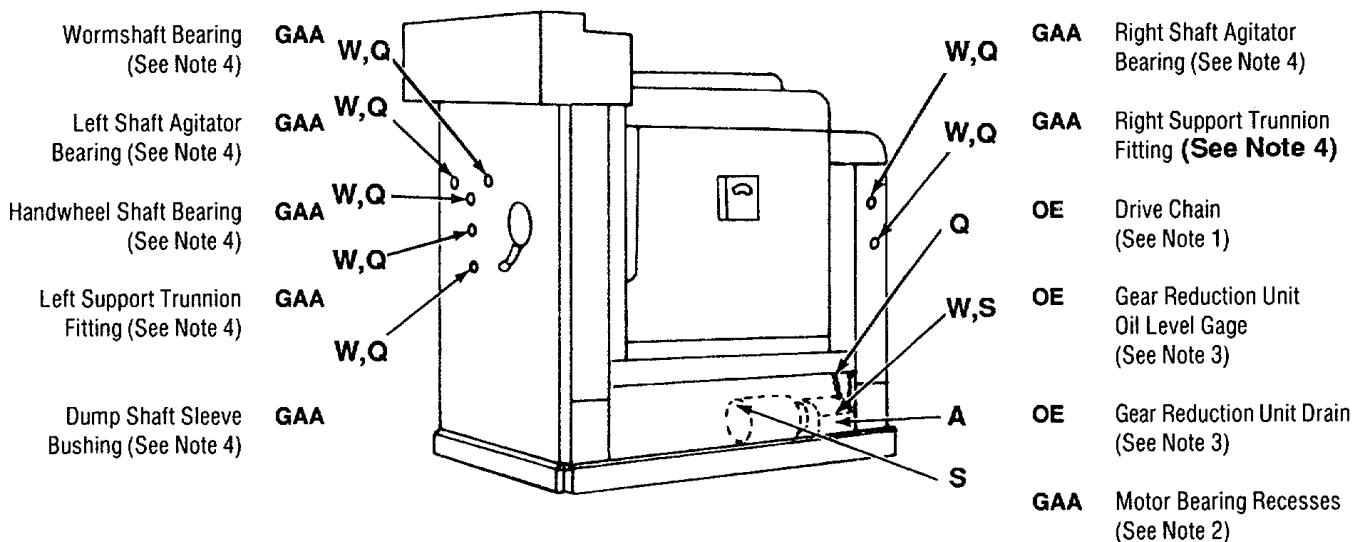

**-KEY-**

LUBRICANTS	EXPECTED TEMPERATURES	INTERVALS
	ALL TEMPERATURES	
<b>OE</b> - LUBRICATING OIL. Internal Combustion Engine	<b>OE 30</b> OR <b>9250</b>	W - Weekly (See notes 3 and 4) M - Monthly Q - Quarterly S - Semi-annually A - Annually
Drive Chain	<b>OE 10</b> OR <b>9110</b>	
<b>GAA</b> - GREASE. Automotive and Artillery	<b>GAA</b>	

NOTES.

1. DRIVE CHAINS Quarterly clean, coat sparingly with OE-10, and wipe oil from outer surface.
2. MOTOR BEARING RECESSES. Semiannually add GAA grease sparingly to seal out moisture
3. GEAR REDUCTION UNIT Every 5 days when unit is in continuous use (and after operation), check oil level and keep level up to center of gage. When use is less than once every 7 days semiannually check oil level and keep level up to center of gage. Annually drain oil, remove top of reduction unit, and refill with OE-30
4. LUBRICATE. Once every 5 days when unit is In continuous use (and after operation). Lubricate quarterly when use is less than once every 7 days.

Copy of this Lubrication Order will remain with the equipment at all times; instructions contained herein are mandatory

**By Order of the Secretary of the Army:**

**CARL E. VUONO**  
*General, United States Army*  
*Chief of Staff*

**Official:**

**THOMAS F. SIKORA**  
*Brigadier General, United States Army*  
*The Adjutant General*

**DISTRIBUTION:**

To be distributed in accordance with DA Form 12-25E, (Qty rqr blk no. 4069).

RECOMMENDED CHANGES TO EQUIPMENT TECHNICAL PUBLICATIONS



THEN...JOT DOWN THE  
DOPE ABOUT IT ON THIS FORM.  
CAREFULLY TEAR IT OUT, FOLD IT  
AND DROP IT IN THE MAIL.

# SOMETHING WRONG WITH PUBLICATION

FROM: (PRINT YOUR UNIT'S COMPLETE ADDRESS)

DATE SENT

PUBLICATION NUMBER

PUBLICATION DATE

PUBLICATION TITLE

BE EXACT PIN-POINT WHERE IT IS

PAGE  
NO.

PARA-  
GRAPH

FIGURE  
NO.

TABLE  
NO.

IN THIS SPACE, TELL WHAT IS WRONG  
AND WHAT SHOULD BE DONE ABOUT IT.

PRINTED NAME, GRADE OR TITLE AND TELEPHONE NUMBER

SIGN HERE

